



GEMINI TECHNOLOGY CO., LTD

SPECIFICATION FOR LCD MODULE

MODULE NO.: TM0027-Z-LED

Customer NO. :

REVISION :00

GEMINI	PREPARED BY	CHECKED BY	APPROVED BY
SIGNATURE	Aojun	Dairuida	Zhouxinping
DATE	Feb-5-2015	Feb-5-2015	Feb-5-2015

CUSTOMER APPROVAL	SIGNATURE	DATE

Note:

This specification is subject to change without prior notice in order to improve performance or quality etc. please contact GEMINI TECHNOLOGY CO.,LTD to confirm the latest revision.

GEMINI Technology Co., Ltd.

RM1521 Investel, 1123-2 Sanbon-Dong, Gunpo-City, Kyeonggi-Do Korea

Tel : +82-31-455-3200(Rep.) Fax : +82-31-343-2102

E-mail : sales@FindLCD.com

Http://www.FindLCD.com



GEMINI TECHNOLOGY CO., LTD

DOCUMENT REVISION HISTORY

Version	DATE	DESCRIPTION	CHANGED BY
00	Feb-5-2015	First issue	Aojun



CONTENTS

1. FUNCTIONS & FEATURES..... 1

2. MECHANICAL SPECIFICATIONS 1

3. BLOCK DIAGRAM..... 1

4. DIMENSIONAL OUTLINE 2

5. PIN DESCRIPTION 3

6. LCD Driving voltage generator and bias reference circuit..... 4

7. MAXIMUM ABSOLUTE LIMIT 5

8. ELECTRICAL CHARACTERISTICS..... 6

9. TIMING CHARACTERISTICS..... 7

10.ELECTRO-OPTICAL CHARACTERISTICS 8

11. CONTROL AND DISPLAY INSTRUCTION 9

12.PRECAUTION FOR USING LCD/LCM 10

13. LCM TEST CRITERIA..... 12

1. FUNCTIONS & FEATURES

- 1.1. Format : 128*64 Dots
- 1.2. LCD mode : FSTN/Positive/Transflective
- 1.3. Viewing direction : 6 o'clock
- 1.4. Driving scheme : 1/65 Duty, 1/9 Bias
- 1.5. Power supply voltage (V_{DD}) : 3.0V
- 1.6. LCD driving voltage : 9.2V (REF.)
- 1.7. Operation temp : -20~70°C
- 1.8. Storage temp : -30~80°C
- 1.9. RoHS standard

2. MECHANICAL SPECIFICATIONS

- 2.1. Module size : 38.3mm(L)*33.0m(W)[without FPC]*2.08 mm (H)
- 2.2. Viewing area : 35.3mm(L)*23.2mm(W)
- 2.3. Active area : 30.705mm(L)*19.185mm(W)
- 2.4. Dot pitch : 0.24mm(L)*0.30mm(W)
- 2.5. Dot size : 0.225mm(L)*0.285mm(W)
- 2.6. Weight : Approx.

3. BLOCK DIAGRAM

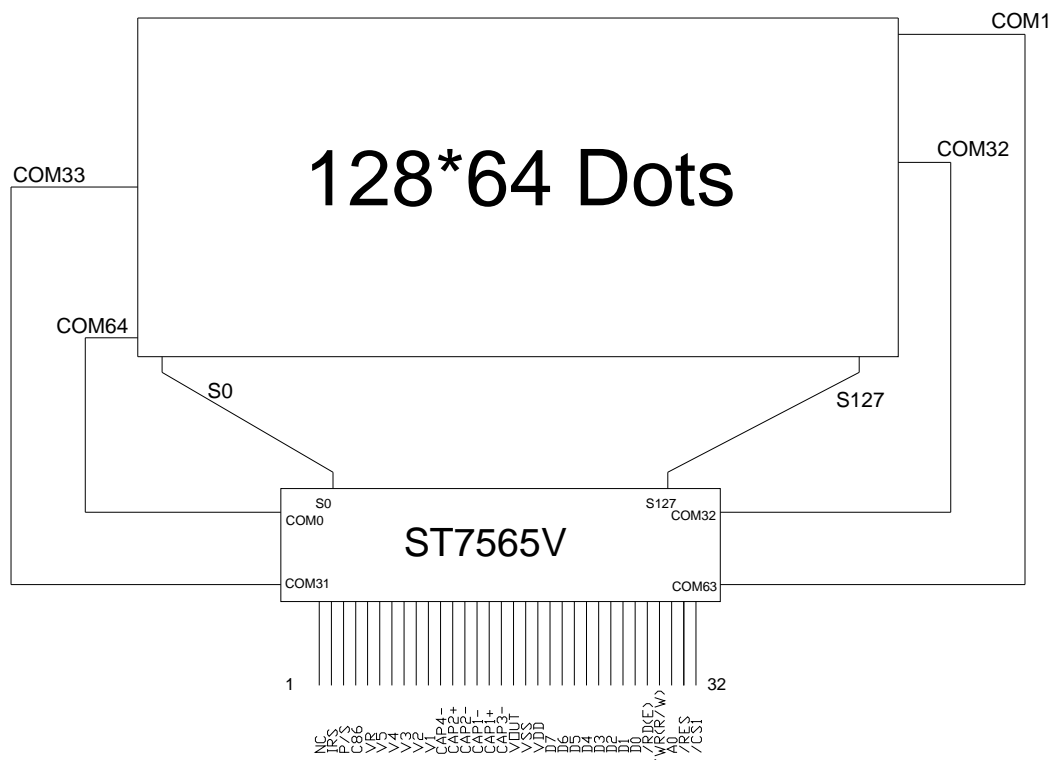

Figure 1. Block diagram

4. DIMENSIONAL OUTLINE

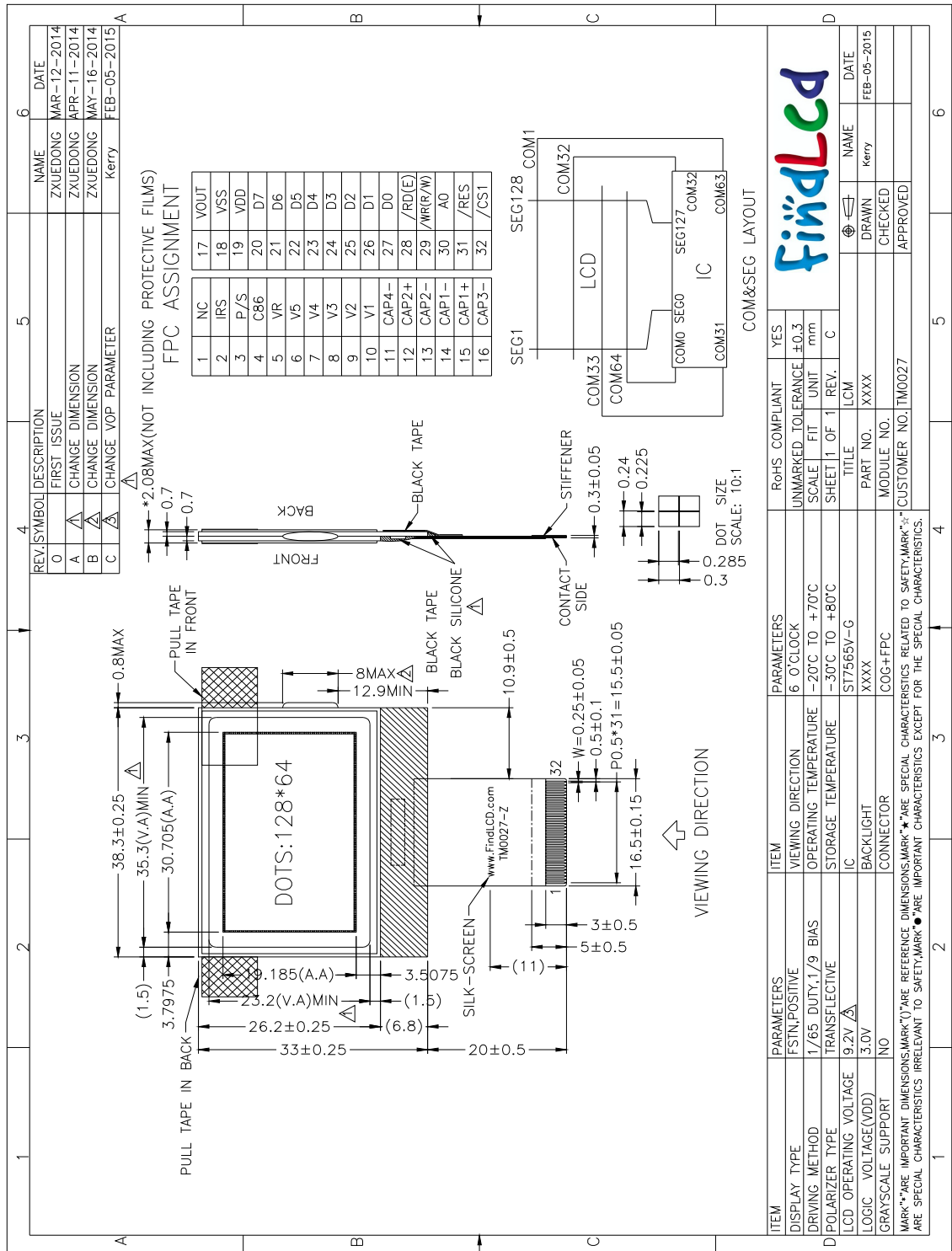
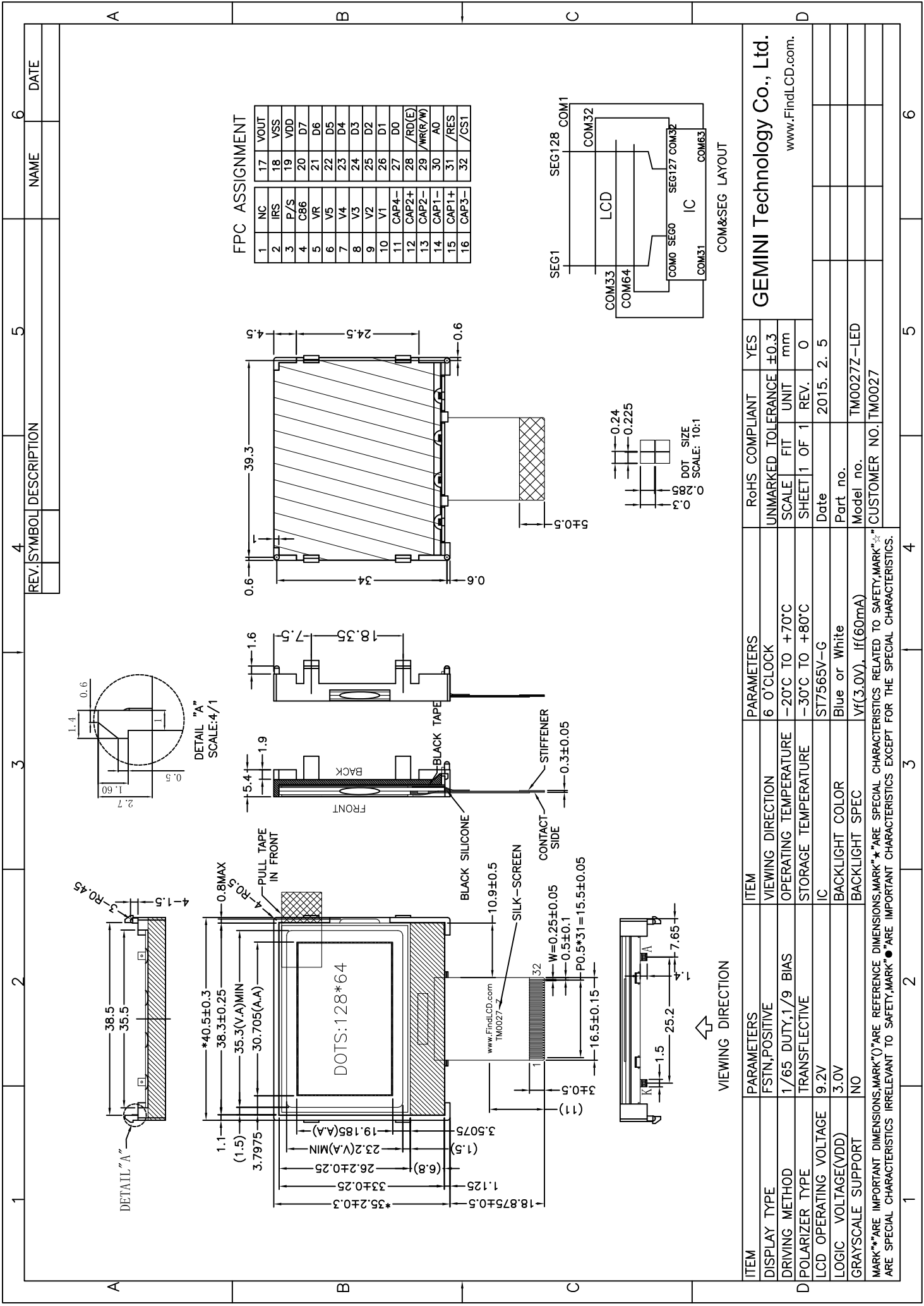

Figure 2. Dimensional outline



1	2	3	4	5	6
REV.	SYMBOL	DESCRIPTION	NAME	DATE	

ITEM	PARAMETERS	ITEM	PARAMETERS	RoHS COMPLIANT	YES
DISPLAY TYPE	FSTN, POSITIVE	VIEWING DIRECTION	6 O'CLOCK	UNMARKED TOLERANCE	±0.3
DRIVING METHOD	1/65 DUTY, 1/9 BIAS	OPERATING TEMPERATURE	-20°C TO +70°C	SCALE	FIT UNIT mm
POLARIZER TYPE	TRANSFLECTIVE	STORAGE TEMPERATURE	-30°C TO +80°C	SHEET 1 OF 1	REV. 0
LCD OPERATING VOLTAGE	9.2V	IC	ST7565V-G	Date	2015. 2. 5
LOGIC VOLTAGE(VDD)	3.0V	BACKLIGHT COLOR	Blue or White	Part no.	
GRAYSCALE SUPPORT	NO	BACKLIGHT SPEC	Vf(3.0V), If(60mA)	Model no.	TM0027Z-LED
MARK**ARE IMPORTANT DIMENSIONS, MARK(*)ARE REFERENCE DIMENSIONS, MARK**ARE SPECIAL CHARACTERISTICS RELATED TO SAFETY, MARK***ARE SPECIAL CHARACTERISTICS IRRELEVANT TO SAFETY, MARK***ARE IMPORTANT CHARACTERISTICS EXCEPT FOR THE SPECIAL CHARACTERISTICS.					
				CUSTOMER NO.	TM0027
				www.FindLCD.com	

GEMINI Technology Co., Ltd.
www.FindLCD.com

COM&SEG LAYOUT

VIEWING DIRECTION

SCALE: 10:1

DOT SIZE

SCALE: 10:1

5. PIN DESCRIPTION

No.	Symbol	Function
1	NC	No Connection
2	IRS	This terminal selects the resistors for the V5 voltage level adjustment, IRS = "H": Use the internal resistors
3	P/S	This is the parallel data input/serial data input switch terminal. P/S = "H": Parallel data input.
4	C86	This is the MPU interface switch terminal. C86 = "L": 8080 MPU interface.
5	VR	Output voltage regulator terminal. Provides the voltage between VDD and V5 through a resistive voltage divider. IRS = "H" : the V5 voltage regulator internal resistors are used .
6-10	V5-V1	This is a multi-level power supply for the liquid crystal drive.
11	CAP4-	DC/DC voltage converter. Connect a capacitor between this terminal and the CAP2+ terminal.
12	CAP2+	DC/DC voltage converter. Connect a capacitor between this terminal and the CAP2- terminal.
13	CAP2-	DC/DC voltage converter. Connect a capacitor between this terminal and the CAP2+ terminal.
14	CAP1-	DC/DC voltage converter. Connect a capacitor between this terminal and the CAP1+ terminal.
15	CAP1+	DC/DC voltage converter. Connect a capacitor between this terminal and the CAP1- terminal.
16	CAP3-	DC/DC voltage converter. Connect a capacitor between this terminal and the CAP1+ terminal.
17	VOUT	DC/DC voltage converter. Connect a capacitor between this terminal and VSS.
18	VSS	Power GND.
19	VDD	Power Supply (+3.0V).
20-27	D7~D0	Data bus
28	/RD(E)	8080 Series: this is the read control signal.
29	/WR(R/W)	8080 Series: this is the write control signal.
30	A0	This is connected to the least significant bit of the normal MPU address bus, and it determines whether the data bits are data or a command.
31	/RES	Reset signal.
32	/CS1	Chip select signal.

6. LCD Driving voltage generator and bias reference circuit

1. used all of the step-up circuit, voltage regulating circuit and V/F circuit

(1) When the voltage regulator internal resistor is used.

(Example where $VSS2 = VSS$, with 4x step-up)

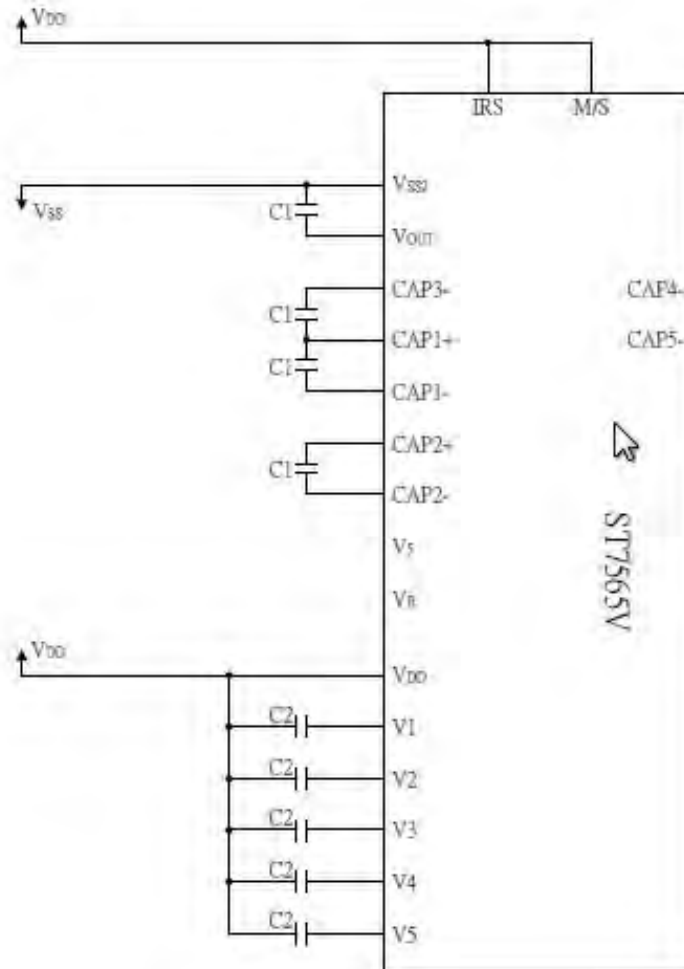

NOTE:

■ Recommended component values:

$C1$: 1.0 to 4.7 μ F; $C2$: 0.1~0.47 μ F

■ $C1, C2$ is determined by the size of the LCD being driven. Select a value that will stabilize the liquid crystal drive voltage.

7. MAXIMUM ABSOLUTE LIMIT

Item	Symbol	MIN	MAX	Unit
Power supply voltage	VSS	-3.6	0.3	V
Power supply voltage (VDD standard)	VSS2	-3.6	0.3	V
Power supply voltage (VDD standard)	V5, VOUT	-13.5	0.3	V
Power supply voltage (VDD standard)	V1, V2, V3, V4	V5	0.3	V
Input Voltage	VIN	-0.3	VDD+0.3	V
Output voltage	VO	-0.3	VDD+0.3	V
Supply Current(without B/L)	$I_{DD}(T_a = 25^{\circ}\text{C})$	---	2	mA
Operating Temperature	Top	-20	70	°C
Storage Temperature	Tst	-30	80	°C

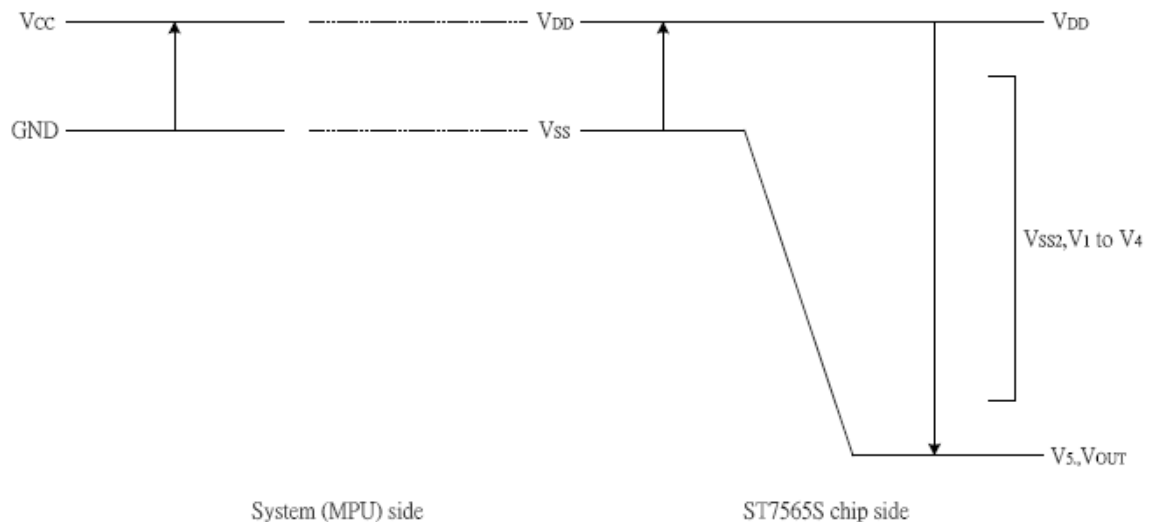

Notes and Cautions

1. The VSS2, V1 to V5 and VOUT are relative to the VDD = 0V reference.
2. Insure that the voltage levels of V1, V2, V3, and V4 are always such that $V_{DD} \geq V_1 \geq V_2 \geq V_3 \geq V_4 \geq V_5$.
3. Permanent damage to the LSI may result if the LSI is used outside of the absolute maximum ratings. Moreover, it is recommended that in normal operation the chip be used at the electrical characteristic conditions, and use of the LSI outside of these conditions may not only result in malfunctions of the LSI, but may have a negative impact on the LSI reliability as well.

8. ELECTRICAL CHARACTERISTICS

DC Characteristics

Unless otherwise specified, VSS = -3.0V, VDD = 0V, Ta = -20 to 70°C

Item	Symbol	Condition	Rating			Units	Applicable Pin		
			Min.	Typ.	Max.				
Operating Voltage (1)	VSS		-3.3	—	-1.8	V	VSS*1		
Operating Voltage (2)	VSS2	(Relative to VDD)	-3.3	—	-2.4	V	VSS2		
Operating Voltage (3)	VSS2	(Relative to VDD)	-12.0	—	-4.0	V	V5 *2		
			0.4 x V5	—	VDD		V1, V2		
			V5	—	0.6 x V5		V3, V4		
High-level Input Voltage	VIHC		0.8 x VDD	—	VDD	V	*3		
Low-level Input Voltage	VILC		VSS	—	0.2 x VDD	V	*3		
High-level Output Voltage	VOHC	IOH = -0.5 mA	0.8 x VDD	—	VDD	V	*4		
Low-level Output Voltage	VOLC	IOL = 0.5 mA	VSS	—	0.2 x VDD	V	*4		
Input leakage current	ILI	VIN = VDD or VSS	-1.0	—	1.0	μA	*5		
Output leakage current	ILO	VIN = VDD or VSS	-3.0	—	3.0	μA	*6		
Liquid Crystal Driver ON Resistance	RON	Ta = 25°C (Relative To VDD)	V5 = -13.0 V	—	2.0	3.5	KΩ	SEgN COMn *7	
			V5 = -8.0 V	—	3.2	5.4			
Static Consumption Current	ISSQ	V5 = -13.0V (Relative to VDD)	—	0.01	2	μA	VSS, VSS2		
Output Leakage Current	ISQ		—	0.01	10	μA	V5		
Input Terminal Capacitance	CIN	Ta = 25°C, f = 1 MHz	—	5.0	8.0	pF			
Oscillator Frequency	Internal Oscillator	fOSC	1/65 duty 1/33 duty	Ta = 25°C	17	20	24	kHz	*8
	External Input	fCL			17	20	24	kHz	CL
	Internal Oscillator	fOSC	1/49 duty 1/53 duty	Ta = 25°C	25	30	35	kHz	*8
	External Input	fCL			25	30	35	kHz	CL

Item	Symbol	Condition	Rating			Units	Applicable Pin
			Min.	Typ.	Max.		
Internal Power	Input voltage	VSS2 (Relative To VDD)	-3.3	—	-2.4	V	VSS2
	Supply Step-up output voltage Circuit	VOUT (Relative To VDD)	-13.5	—	—	V	VOUT
	Voltage regulator Circuit Operating Voltage	VOUT (Relative To VDD)	-13.5	—	-6.0	V	VOUT
	Voltage Follower Circuit Operating Voltage	V5 (Relative To VDD)	-12.0	—	-4.0	V	V5 * 9
	Base Voltage	VRS	Ta = 25°C, (Relative To VDD) -0.05%/°C	-2.07	-2.10	-2.13	V

9. TIMING CHARACTERISTICS

System Bus Read/Write Characteristics 1 (For the 8080 Series MPU)

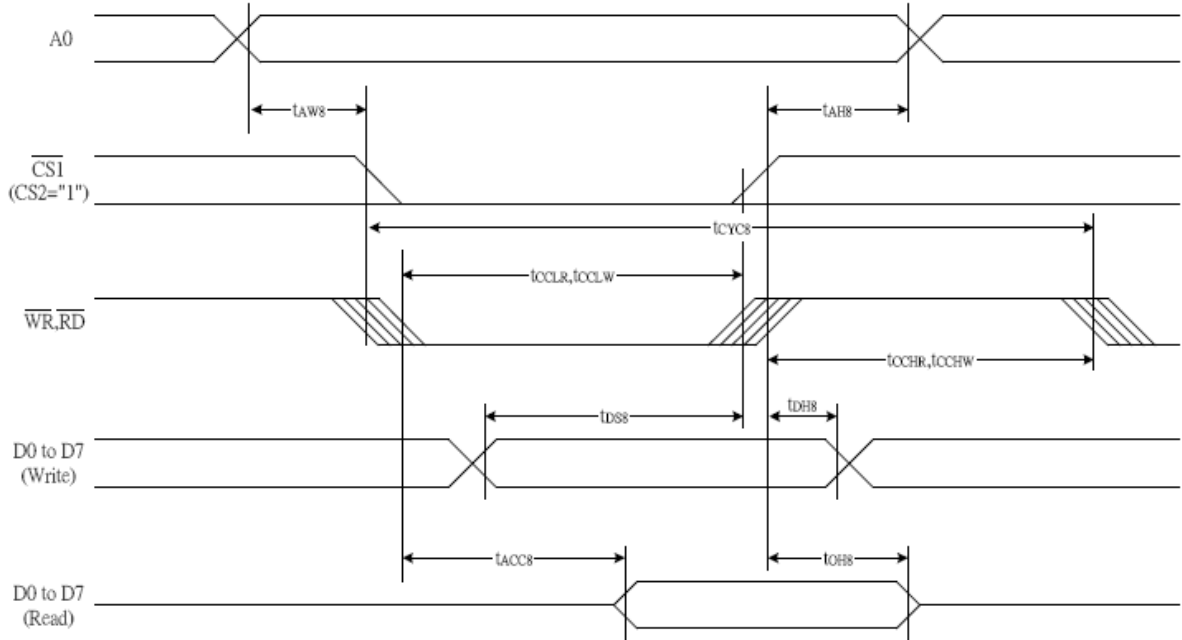

(VDD=3.0V, Ta= -20 to 70°C)

Item	Signal	Symbol	Condition	Rating		Units
				Min.	Max.	
Address hold time	A0	tAH8		0	—	Ns
Address setup time		tAW8		0	—	
System cycle time		tCYC8		240	—	
Enable L pulse width (WRITE)	WR	tCCLW		100	—	
Enable H pulse width (WRITE)		tCCHW		100	—	
Enable L pulse width (READ)	RD	tCCLR		140	—	
Enable H pulse width (READ)		tCCHR		100	—	
WRITE Data setup time	D0 to D7	tDS8		40	—	
WRITE Address hold time		tDH8		10	—	
READ access time		tACC8	CL = 100 pF	—	70	
READ Output disable time		tOH8	CL = 100 pF	5	50	

10.ELECTRO-OPTICAL CHARACTERISTICS

($V_{DD}=3.0V$, $T_a = 25^{\circ}C$)

Item	Symbol	Condition	Min	Typ	Max	Unit
Operating Voltage for LCD	Vop	Ta = -20°C	9.1	9.4	9.7	V
		Ta = 25°C	8.9	9.2	9.5	
		Ta = 70°C	8.7	9.0	9.3	
Response time	Tr	Ta = 25°C	---	200	---	ms
	Tf		---	350	---	ms
Contrast	Cr	Ta = 25°C	---	4.5	---	---
Viewing angle range	θ_{x-}	Cr ≥ 2	30	35	---	deg
	θ_{x+}		30	35	---	deg
	θ_{y-}		35	45	---	deg
	θ_{y+}		35	40	---	deg

$$Cr = \frac{\text{Brightness of non-selected segment}(B2)}{\text{Brightness of selected segment}(B1)}$$

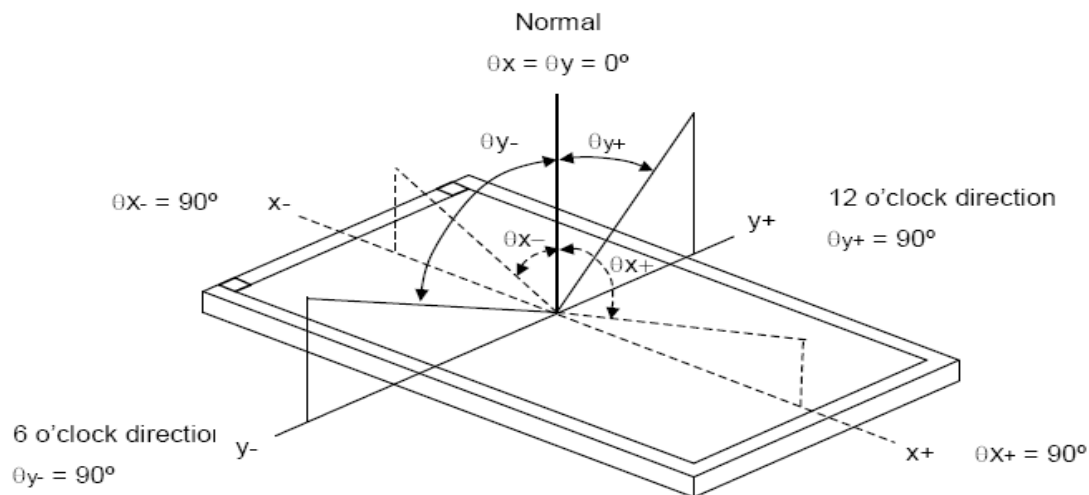

11. CONTROL AND DISPLAY INSTRUCTION

Command	Command Code									Function		
	A0	/RD	/WR	D7	D6	D5	D4	D3	D2		D1	D0
(1) Display ON/OFF	0	1	0	1	0	1	0	1	1	1	0	1
(2) Display start line set	0	1	0	0	1	Display start address						
(3) Page address set	0	1	0	1	0	1	1	Page address				
(4) Column address set upper bit	0	1	0	0	0	0	1	Most significant column address				
Column address set lower bit	0	1	0	0	0	0	0	Least significant column address				
(5) Status read	0	0	1	Status				0	0	0	0	
(6) Display data write	1	1	0	Write data								
(7) Display data read	1	0	1	Read data								
(8) ADC select	0	1	0	1	0	1	0	0	0	0	0	1
(9) Display normal/reverse	0	1	0	1	0	1	0	0	1	1	0	1
(10) Display all points ON/OFF	0	1	0	1	0	1	0	0	1	0	0	1
(11) LCD bias set	0	1	0	1	0	1	0	0	0	1	0	1
(12) Read/modify/write	0	1	0	1	1	1	0	0	0	0	0	0
(13) End	0	1	0	1	1	1	0	1	1	1	0	
(14) Reset	0	1	0	1	1	1	0	0	0	1	0	
(15) Common output mode select	0	1	0	1	1	0	0	0	*	*	*	1
(16) Power control set	0	1	0	0	0	1	0	1	Operating mode			
(17) Vs voltage regulator internal resistor ratio set	0	1	0	0	0	1	0	0	Resistor ratio			
(18) Electronic volume mode set	0	1	0	1	0	0	0	0	0	0	0	1
Electronic volume register set				0	0	Electronic volume value						
(19) Static indicator ON/OFF	0	1	0	1	0	1	0	1	1	0	0	1
Static indicator register set				0	0	0	0	0	0	0	0	Mode
(20) Booster ratio set	0	1	0	1	1	1	1	1	0	0	0	
				0	0	0	0	0	0	0	0	step-up value
(21) Power saver												
(22) NOP	0	1	0	1	1	1	0	0	0	1	1	
(23) Test	0	1	0	1	1	1	1	*	*	*	*	

12.PRECAUTION FOR USING LCD/LCM

LCD/LCM is assembled and adjusted with a high degree of precision. Do not attempt to make any alteration or modification. The followings should be noted.

General Precautions:

1. LCD panel is made of glass. Avoid excessive mechanical shock or applying strong pressure onto the surface of display area.
2. The polarizer used on the display surface is easily scratched and damaged. Extreme care should be taken when handling. To clean dust or dirt off the display surface, wipe gently with cotton, or other soft material soaked with isopropyl alcohol or ethyl alcohol, do not use water, ketone or aromatics and never scrub hard.
3. Do not tamper in any way with the tabs on the metal frame.
4. Do not made any modification on the PCB without consulting GEMINI.
5. When mounting a LCM, make sure that the PCB is not under any stress such as bending or twisting. Elastomer contacts are very delicate and missing pixels could result from slight dislocation of any of the elements.
6. Avoid pressing on the metal bezel, otherwise the elastomer connector could be deformed and lose contact, resulting in missing pixels and also cause rainbow on the display.
7. Be careful not to touch or swallow liquid crystal that might leak from a damaged cell. Any liquid crystal adheres to skin or clothes, wash it off immediately with soap and water.

Static Electricity Precautions:

1. CMOS-LSI is used for the module circuit; therefore operators should be grounded whenever he/she comes into contact with the module.
2. Do not touch any of the conductive parts such as the LSI pads; the copper leads on the PCB and the interface terminals with any parts of the human body.
3. Do not touch the connection terminals of the display with bare hand; it will cause disconnection or defective insulation of terminals.
4. The modules should be kept in anti-static bags or other containers resistant to static for storage.
5. Only properly grounded soldering irons should be used.
6. If an electric screwdriver is used, it should be grounded and shielded to prevent sparks.
7. The normal static prevention measures should be observed for work clothes and working benches.
8. Since dry air is inductive to static, a relative humidity of 50-60% is recommended.

Soldering Precautions:

1. Soldering should be performed only on the I/O terminals.
2. Use soldering irons with proper grounding and no leakage.
3. Soldering temperature: 300 ± 5 °C
4. Soldering time: 2 to 3 second.
5. Use eutectic solder with resin flux filling.
6. If flux is used, the LCD surface should be protected to avoid spattering flux.
7. Flux residue should be removed.



Operation Precautions:

1. The viewing angle can be adjusted by varying the LCD driving voltage V_o .
2. Since applied DC voltage causes electro-chemical reactions, which deteriorate the display, the applied pulse waveform should be a symmetric waveform such that no DC component remains. Be sure to use the specified operating voltage.
3. Driving voltage should be kept within specified range; excess voltage will shorten display life.
4. Response time increases with decrease in temperature.
5. Display color may be affected at temperatures above its operational range.
6. Keep the temperature within the specified range usage and storage. Excessive temperature and humidity could cause polarization degradation, polarizer peel-off or generate bubbles.
7. When storing the LCD modules, avoid exposure to direct sunlight or to the light of fluorescent lamps. For long-term storage, the temperature should be $0^{\circ}\text{C}\sim 40^{\circ}\text{C}$, and the relative humidity should be kept 40%~60%.

Limited Warranty

GEMINI LCDs and modules are not consumer products, but may be incorporated by GEMINI's customers into consumer products or components thereof, GEMINI does not warrant that its LCDs and components are fit for any such particular purpose.

1. The liability of GEMINI is limited to repair or replacement on the terms set forth below. GEMINI will not be responsible for any subsequent or consequential events or injury or damage to any personnel or user including third party personnel and/or user. Unless otherwise agreed in writing between GEMINI and the customer, GEMINI will only replace or repair any of its LCD which is found defective electrically or visually when inspected in accordance with GEMINI general LCD inspection standard . (Copies available on request)
2. No warranty can be granted if any of the precautions state in handling liquid crystal display above has been disregarded. Broken glass, scratches on polarizer mechanical damages as well as defects that are caused accelerated environment tests are excluded from warranty.
3. In returning the LCD/LCM, they must be properly packaged; there should be detailed description of the failures or defect.

13. LCM TEST CRITERIA

1. Objective

The LCM test criteria are set to formalize GEMINI's LCM quality standards with reference to those of the customer for inspection, release and acceptance of finished LCM products in order to guarantee the quality required by the customer.

2. Scope

The criteria are applicable to all the LCM products manufactured by GEMINI.

3. Equipments for Inspection

Electrical testing machines, vernier calipers, ampere meter, multi-meter, microscopes, anti-static wrist straps, finger cots, labels, tri-phase thermal shock chamber, constant temperature and humidity chamber, high-low temperature experimenting box, refrigerators, constant voltage power supply (DC)), desk Lamps, etc.

4. Sampling Plan and Reference Standards

4.1.1 Based on GB/T 2828.1---2003/ISO2859-1:1999:

Inspection items	Sampling Rate	AQL Assessment
Appearance	Normally checking the sampling plan one time and performing general inspection level II	MA=0.4 MI=1.0
Function	Normally checking the sampling plan one time and performing general inspection level II	MA=0.4 MI=1.0
Size	N=3	C=0

4.1.2 GB/T 2828.1---2003/ISO2859-1:1999 checking the counting sampling procedure and sampling table.

4.1.3 GB/T 1619.96: Test methods for TN LCD parts.

4.1.4 GB/T 12848.91: General Specification for STN LCD parts

4.1.5 GB2421-89: Basic Environmental Test Procedures for Electrical and Electronic Products

4.1.6 IPC-A-610C: The acceptance condition for electrician assembled.

5. Inspection Conditions and Inspection Reference

5.1 Cosmetic inspection: shall be done normally at $25\pm 5^{\circ}\text{C}$ of the ambient temperature and $45\pm 20\%$ RH of relative humidity, under the ambient luminance greater than 300lux and at the distance of 30cm apart between the inspector's eyes and the LCD panel and normally in reflected light. For back-lit LCMs, cosmetic inspection shall be done under the ambient luminance less than 100lux with the backlight on.

5.2 The LCM shall be tested at the angle of 45° both left side and right side, and 0-45° both top side and bottom side (for STN LCM, at 20°~55°):

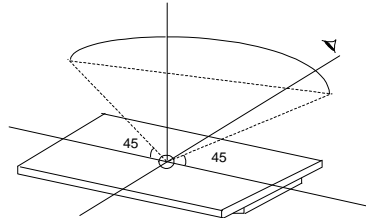

5.3 Definition of VA

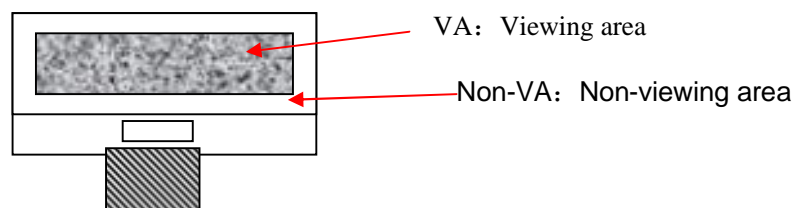

- 5.4 Inspection with naked eyes (exclusive of the inspection of the physical dimensions of defects carried out with magnifiers) .
- 5.5 Electrical properties: Inspection with the self-made/special LCM test jigs against the product documents or drawings; display contents and parameters shall conform to their documents requirements and the display effect to the drawing.
- 5.5.1 Test voltage (V) : (Determined) according to the operating instruction of test jigs assuming the external circuit can be adjusted unless the customer otherwise specifies driving voltage(s). (Display) effects are controlled within the specified range of voltage variation (If no specific requirements, display effects are controlled at $V_{op} = 9V$ or $V_{op} \pm 0.3V$ when V_{op} is below 9V; if V_{op} is above 9V, display effects are controlled at $V_{op} \pm 3\%$ at least).For display products with the customer-specified fixed V_{op} , display effects are controlled by adjusting the internal circuit; if necessary, acceptable limit samples shall be built.
- 5.5.2 Current Consumption (I) : Refer to approved product specifications or drawings.
- 5.5.3 Size: for the outline dimension and the position which maybe affect customer assembled all should conform to the technical drawing requirements.

6. Defects and Acceptance Standards

6.1 Electrical properties test

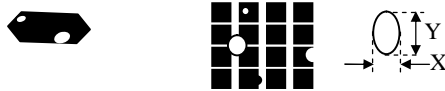
No.	Defects	Description	Accepted standard	MAJ	MIN
6.1.1	Missing segment	SEG/COM dot and character missing segment caused by its wire broken/poor contact(s) and internal open circuit. 	Reject	√	
6.1.2	No display/ reaction	The products no picture display under normally connected situation.	Reject	√	
6.1.3	Mis-dispaly/ abnormally display	Displaying pattern and sequence not conform to the requirement or abnormally display when scanning as per the correct procedure.	Reject	√	
6.1.4	Wrong viewing angle	When powered on, the clearest viewing direction of display pattern is not conform to the requested one(or not conform the direction of the customer approved samples)	Reject	√	
6.1.5	Dim or dark display	Overall contrast is either too dark or too dim under normal operation	Beyond the voltage tolerance, reject	√	
6.1.6	Responded slowly	When power on or off some parts response time is different from others.	Reject	√	
6.1.7	Exceed segment	As misalignment and insufficient etching caused abnormally display, display with exceed pattern or display with abnormally symbol, row or columns when power on.	Refer to the dot/line standard		√
6.1.8	Dim segment	Under the normal voltage, the contrast of vertical and horizontal segments is uneven and the depth of display segments with different contrast ratio.	Reject or refer to its samples		√
6.1.9	PI black/ white spot	Partial black and white spots visible when changing display contents due to defective PI layer in the inner of LCD.	Refer to the spot/line criteria for the visible spots when display image remains still; others OK		√
6.1.10	Pinhole /white spot	Fragmental patterns appearing when it powered on caused by missing ITO.  $d = (X+Y)/2$	Refer to the dot/line standard		√

6.1.11	Partten distortion	The pattern displayed width is either wider, narrower or deformed than the specified, caused by its misalignment and resulting in unwanted heave(s) or missing: $ a-b \leq 1/4W$ (W is the normal width)		$ a-b > 1/4W$, Reject		√
6.1.12	High current	The current of LCD is higher than the standard one.		Reject		√
6.1.13	Cross talk	The degree of cross talk should not beyond the limited samples.		Refer to its limited samples	√	

6.2 LCD appearance defect:

6.2.1 Dot and line defects (defined within VA, spots out of VA do not account)

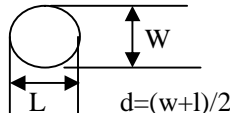
No.	Defects	Average diameter (d)	Acceptable quantity	MAJ	MIN
6.2.1.1	Spot defects (black spot, foreign material, nick, scratches, including LC with wrong orientation)	$d \leq 0.20$	3		√
		$0.20 < d \leq 0.25$	2		
		$0.25 < d \leq 0.30$	1		
		$0.30 < d$	0		
6.2.1.2	Line defects (scratches and line with foreign materials)  Line length=L Line width=W	$W \leq 0.01$	Not counted		√
		$L \leq 3.0, W \leq 0.02$	3		
		$L \leq 3.0, W \leq 0.03$	3		
		$L \leq 3.0, W \leq 0.05$	1		
		Note: when $W > 0.1\text{mm}$ it can regard as spot defect one.			
6.2.1.3	Polarizer with air bubble or convex-concave dots defect 	$d \leq 0.3$	3		√
		$0.3 < d \leq 0.5$	2		
		$0.5 < d \leq 0.8$	0		
Note: each of the same product should not exceed with 4 spot and line defects and the distance between each two spot should $\geq 5\text{mm}$.					

6.2.2 Glass Damages (for LCMs without bezels and whose LCD edges exposed and for LCMs with bezels, including COG, H/S and directly assembled with BL LCMs)

No.	Defects	Acceptance Standard (unit : mm)		MAJ	MIN
6.2.2.1		X	≤ 3.0		√
		Y	$\leq 1/3W$		
		Z	$\leq 1/2t$		
		Acceptable quantity	2		
		When $Y \leq 0.2\text{mm}$, the length of X doesn't count; for chip neither on lead nor through, when $X \leq 1/10L$, $Y \leq 1/2W$ max, it doesn't count.			
6.2.2.2		X	$\leq 1/10L$		√
		Y	$\leq 2/3W$		
		Z	$\leq t$		
		Acceptable quantity	2		
		For chips on the end sealing corners, refer to 6.2.2.3 and they must be out of the frame epoxy. For chips on lead, refer to 6.2.2.1			
6.2.2.3		X	$\leq 1/8L$		√
		Y	$\leq 1/2H$		
		Z	$\leq 1/2t$		
		Acceptable quantity	2		
		The standard for inner chip on sealed area is the same as the standard for outer. For chip on the reverse of ITO contact pad ledge, refer to 6.2.2.1 for chip on the reverse of ITO contact pad ledge for the value of Y.			
<p>Note: X means the length of chip; Y means the width of the chip; Z means the thickness of the chip; W means the width of the stage of the two glasses; L means the length of the glass; H means the distance between the glass edge and the inner side of frame glue; t means the thickness of the glass.</p>					

6.2.3 Others

No.	Defects	Description	Acceptance standard	MAJ	MIN
6.2.3.1	Rain ball/ bottom color	There is two different color in the same one product or the same batch products with two different colors	Reject or refer to the limited samples		√
6.2.3.2	Leaking ink (LC)	/	Reject	√	
6.2.3.3	Without protect film	/	Reject		√
6.2.3.4	Splay mark	Inspecting whether the surface of polarizer with splay marks against the light	Refer to the limited samples		√

6.3 Backlight components:

No.	Defects	Description	Acceptance standard	MAJ	MIN
6.3.1	Backlight not working, wrong color	/	Reject	√	
6.3.2	Color deviation	When powered on, the LCD color differs from its sample and found that the color not conforming to the drawing after testing.	Refer to sample and drawing		√
6.3.3	Brightness deviation	When powered on, the LCD brightness differs from its sample and is found after testing not conforming to the drawing; or if it conforms to the drawing but the brightness over $\pm 30\%$ than its sample.	Refer to sample and drawing		√
6.3.4	Uneven brightness	When powered on, the LCD brightness is uneven on the same LCD and out of the specification of the drawing. The no specification evenness= (the max value- the min value)/ mean value < 70%.	Refer to sample and drawing		√
6.3.5	Spot/line scratch	When power on, it with dirty spot, scratches and so on spot and line defects	Refer to 6.2.1		√
6.3.6	BL wrapped	The BL should paste tightly on the PCB.	The BL can be allowed within 1mm wrapped parts, if them not affect its appearance and outline dimension.		√
6.3.7	Flicker and with LED shade	When power on, each bright source should not with flicker and the brightness should evenness and without LED shades.	Reject	√	

6.4 Metal frame (Metal Bezel)

No.	Defects	Description	Acceptance standard	MAJ	MIN
6.4.1	Material/surface treatment	Metal frame/surface treatment do not conform to the specifications.	Reject	√	
6.4.2	Tab twist inconformity/ Tab not twisted	Wrong twist method or direction and twist tabs are not twisted as required.	Reject	√	
6.4.3	Oxidization	Oxidation on the surface of the metal bezel	Reject		√
6.4.4	Painting peel off, discoloration, dents, and scratches	1) the front surface with painting peel off and scratched can be see the bottom: Dot : $D \leq 0.5\text{mm}$, exceeds 3; Line: length $\leq 3.0\text{mm}$, width $\leq 0.05\text{mm}$, exceeds 2; 2) front dent, air bubble and side with painting peel off which scratched can be see the bottom: Dot: $D \leq 1.0\text{mm}$, exceeds 3; Line: length $\leq 3.0\text{mm}$, width $\leq 0.05\text{mm}$, exceeds	Reject		√

		2.			
6.4.5	Burr	Burr(s) on metal bezel is so long as to get into viewing area.	Reject		√

6.5 PCB/COB

No.	Defects	Description	Acceptance standard	MAJ	MIN
6.5.1	Improper Epoxy Cover	<ol style="list-style-type: none"> 1) Contacts exposure within the white circle for COB chip bonding. 2) The height of epoxy cover is out of the product specifications and drawing. 3) The epoxy cover over the COB chip exceeds the circle by more than 2mm in diameter, which is the maximum distance the epoxy cover is allowed to exceed the circle. 4) Existence of obvious linear mark(s) or chip-exposing pinhole on the epoxy cover. 5) The pinhole diameter on the epoxy over exceeds 0.25mm and there is foreign matter in the pinhole. 	Reject		√
6.5.2	PCB appearance defect	<ol style="list-style-type: none"> 1) Oxidized or contaminated gold fingers on PCB. 2) Bubbles on PCB after reflow-soldering. 3) Exposure of conductive copper foil caused by peeled off or scratched solder-resist coating. For the conductive area of PCB repaired with the solder resist coating material, the diameter ψ of the repaired area on the circuit must not exceed 1.3mm while for the non-conductive area of PCB repaired with the solder resist coating material, the diameter ψ must not exceed 2.6mm; the total number of repaired areas on PCB must be less than 10; otherwise, the PCB must be rejected. 	Reject		√
6.5.3	Wrong or missing Components on PCB	<ol style="list-style-type: none"> 1) Components on PCB are not the same as defined by drawing such as wrong, excessive, missing, or mis-polarized components. (The bias circuit of LCD voltage or the backlight current limiting resistance is not adjusted unless specified by the customer.) 2) The JUMP short on PCB shall conform to the mechanical drawing. If excessive or missing soldering occurs, the PCB shall be rejected. 3) For components particularly required by the customer and specified in the mechanical drawing and/or component specifications, their 	Reject	√	

		specifications must conform to those of the suppliers; otherwise they shall be rejected.			
--	--	--	--	--	--

6.6 Connector and other components

No.	Defects	Description	Acceptance standard	MAJ	MIN
6.6.1	Out of Specification	The specification of connector and other components do not conform to the drawing.	Reject		√
6.6.2	Position and order	Solder position and Pin# 1 should be in the positions specified by the drawing.	Reject		√
6.6.3	Appearance	1) Flux on PCB components and pins. 2) The pin width of a PIN connector exceeds ½ of the specified pin width.	Reject		√
6.6.4	Glue amount	Flat cable connector: as the conducted wire fixed with glue, if the glue not fully covered the exposed wire and the copper part around holes will be rejected.	Reject		√
6.6.5	Through holes blocked	Socket connector: the components can not plug-in units as the through holes blocked and deformation; the locks which with lock catch can not make the external connector to be locked.	Reject		√

6.7 SMT (Refer to IPC-A-610E the second standard if not specified)

No.	Defects	Description	Acceptance standard	MAJ	MIN
6.7.1	Soldering solder defects	Cold, false and missing soldering, solder crack and insufficient solder dissolution.	Reject		√
6.7.2	Solder ball/splash	Solder ball/tin dross causing short circuit at the solder point. There are active solder ball and splash.	Reject		√
6.7.3	DIP parts	Floated or tilted DIP parts, keypad, and connectors.	Reject		√
6.7.4	Solder shape	The welded spot should be concave and excessive or insufficient solder or solder burr on the welded spot must be rejected.	Reject		√
6.7.5	Component pin exposure	For the DIP type components, 0.5~2mm component pin must be remained after cutting the soldered pin and the solder surface neither should not be damaged nor should the component pin is fully covered with solder; otherwise rejected.	Reject		√
6.7.6	Poor Appearance	The LCMs become yellow-brown or black as the residual resin or solder oil. There is white mist residual at the solder point caused by PCB cleaning.	Reject		√

6.8 Hot Pressing components (including H/S, FPC, etc.)

No.	Defects	Description	Acceptance standard	MAJ	MIN
6.8.1	Out of its specification		Reject	√	
6.8.2	Size		Refer to its drawing		√
6.8.3	Position	<p>Note: H=ITO pin length, W=ITO pin width, f= heat seal or the misplaced width of TAB.</p>	<p>1, If $f \leq 1/3w$, $h \leq 1/3H$, and its conform to the size and specification on drawing, which will be received.</p> <p>2, The contact area of dielectric material conductor position and pressing material over 1/2 (controlling as per each ITO position) will be received.</p>		√
6.8.4	Foreign Matter in Hot pressing area	If foreign matter in non-conductive heat compression area shall not cause short, it is OK. If foreign matter in conductive heat compression area does not exceed 50% of the heat pressure area, it is OK.	Receive		√
6.8.5	Fold marks		Refer to the limited samples.		√

6.9 General Appearance

No.	Defects	Description	Acceptance standard	MAJ	MIN
6.9.1	Connection material	Damaged or contaminated FPC or H/S gold fingers or FFC contact pin side with exposed copper foil or base materials. Sharp folds on FPC, FFC, COF, H/S (unless designed for). Solder paste larger than 2/3 of pin width on the gold finger of FPC and PCB. Pierced or folded FPC/FFC exceeding limit sample.	Reject		√
6.9.2	Poor reinforcing band	The protect tape using for reinforce which not complete covered the needed protection circuits (such as H/S, FFC, FPC, etc.) or it not joint with its pasted material or it glued on the output side of pins.	Reject		√
6.9.3	Surface dirt	The surface of finished LCMs with smudge, residual glue, and finger prints, etc; solder spatters or solder balls on non-soldered area of PCB/COB. Non-removed defect mark or label on LCMs.	Reject		√
6.9.4	Assembly black spot	Smears or black spots found on LCMs after backlight or diffusion barrier are assembled.	Refer to 6.2.1		√

6.9.5	Product mark	Missing, unclear, incorrect, or misplaced part numbers and/or batch marks.	Reject		√
6.9.6	Inner packing	Packing being inconsistent with quantity and part number on packing label, specifications or the customer order - either short-packed or over-packed.	Reject		√

7. Reliability test

Test items	Condition	Time (hrs)	Acceptable standard
High Storage Temp.	80°C	240	Its function and appearance qualified before and after test
High Operating Temp.	70°C		
Low Storage Temp.	-30°C		
Low Operating Temp.	-20°C		
Temp& Humidity Test	60°C,90%RH		
Thermal Shock	-30°C ← 25°C → +80C (30 min ← 10 min → 30min) raising its temperature 5°C/min	10 cycles	

Note1: The temperature allowable deviation is $\pm 5^{\circ}\text{C}$ and the humidity allowable deviation is $\pm 5\% \text{RH}$.

8. Packing

- 8.1 The acceptance inspection of product packing shall meet design requirements. The product packaging label shall bear not only product name, part number, quantity, product date code but also QA's qualifying stamp for each production stage. Incomplete or wrong label shall be unacceptable.
- 8.2 When there are problems with packing safety conformity such as shock resistance, moisture resistance, anti ESD and press resistance, packing shall be disqualified.
- 8.3 When customer's special requirements for packing confirmed and accepted by GEMINI, packing shall be inspected and released according to them.
- 8.4 RoHS and non-RoHS compliant products shall be labeled clearly and separately. Unless otherwise specified by the customer, "RoHS" labels shall be used for all RoHS compliant products.

9. Others

- 9.1 Items not specified in this document or released on compromise should be inspected with reference to mutual agreement and limit samples.